

i320 SIMPLIFIED MANUAL

1. PRODUCT LIST
2. PRODUCT SPECIFICATIONS
3. ERROR DISPLAY
4. SERVICE MODE (test print, EEPROM initialization, destination setting)
5. EXTERNAL VIEW / PARTS LIST
6. TROUBLESHOOTING FLOWCHART
7. SERVICE INFORMATION

APPENDIX 1: SHIPMENT INSPECTION PATTERN

APPENDIX 2: i320 SERVICE TOOL

QY8-1383-000

Rev. 00

September 4, 2002

Canon Inc.

1. PRODUCT LIST

1-1. Main Units

Product name	Product code	Sales Territory	Remarks
Canon Bubble Jet Printer i320	7816A001AA	US	
	7816A002AA	CA	
	7816A003AA	LAM LVT	
	7816A004AA	LAM HVT	
	7816A005AA	AR	
	7816A006AA	EUR	
	7816A007AA	DE	
	7816A008AA	FR	
	7816A009AA	ASA HVT	
	7816A010AA	AU	
	7816A011AA	GB	
	7816A012AA	TW	
	7816A013AA	HK	
	7816A014AA	CN	
7816A015AA	KR		
Canon Bubble Jet Printer PIXUS 320i	7816A016AA	JAPAN	

1-2. Options

None

1-3. Consumables

Product name	Product code	Sales Territory	Remarks
Canon Ink Tank BCI-24 Black	6881A001AA	JPN	Common with S200/S200x/S300 /S330
	6881A002AA	EUR	
	6881A003AA	USA/CAN	
	6881A004AA	ASIA/AUST	
Canon Ink Tank BCI-24 Color	6882A001AA	JPN	
	6882A002AA	EUR	
	6882A003AA	USA/CAN	
	6882A004AA	ASIA/AUST	
Canon Ink Tank BCI-24 Black Twin Pack	6881A008AA	JPN	
	6881A009AA	EUR	
	6881A010AA	USA/CAN	
	6881A011AA	ASIA/AUST	
Canon Ink Tank BCI-24 Color Twin Pack	6882A008AA	JPN	
	6882A009AA	EUR	
	6882A010AA	USA/CAN	
	6882A011AA	ASIA/AUST	

2. PRODUCT SPECIFICATIONS

2-1. Printer Main Unit Specifications

Paper feeding method	ASF
Resolution	2,400dpi x 1,200dpi (at the highest resolution)
Printing speed	
HQ	CL BK
HS	CL BK
	3 ppm (CL through-put pattern) 7 ppm (BK through-put pattern) 6 ppm (CL through-put pattern) 10 ppm (BK through-put pattern)
Printing direction	Bi-directional / Uni-directional (automatically switched according to print data and print mode)
Print width	203.2mm (8 inches)
Interface	USB (2.0) *Full Speed only
Supported print head	Custom color cartridge only (service part: QY6-0044-000)
No. of pages that can be printed	
CL	CL: Approx. 170 pages, BK: Approx. 520 pages (SCID No.5 pattern, default print mode)
BK	BK: Approx. 300 pages (1500 character pattern, default print mode) Approx. 320 pages (JEIDA std. J1 pattern, default print mode)
ASF stacking capacity	Max. 10mm (Approx. 100 pages of 75g/m ²)
Paper weight	64 to 105 g/m ²
Plain paper	10mm or less
High resolution paper	10mm (Approx. 80 sheets) or less
Glossy photo paper	10 sheets or less
Professional photo paper / super photo paper / matte photo paper	A4/LTR/2L 10 sheets or less L/4x6 20 sheets or less
Glossy film	1 sheet
Transparency	30 sheets or less
Postcard for ink jet printer / postcard	40 sheets or less
Professional photo postcard / glossy postcard	20 sheets or less
Envelop	10 sheets or less
Professional photo card (PC-101)	L/C/S(4x6) 20 sheets or less 2L/D/W 10 sheets or less
Glossy photo card	20 sheets or less
T-shirt transfer	1 sheet
Mouse pad	1 piece
Borderless printing	Postcard / L-size paper / 4x6
Detection function	
Cover open	Available
Presence of print head	Available
Presence of ink tank	Not available
Paper out	Available
Paper width	Not available
Waste ink full	Available
Ink remaining amount	Available (Detected by dot counting. Reset by user operation. Default on.)
Head alignment	Available (6 types)
Acoustic noise level	
Fine (glossy paper / high mode)	Approx. 45 dB (Sound pressure level ISO9296)
HQ	Approx. 50 dB
HS	Approx. 53 dB
Environmental requirements	
During operation	Temperature 5°C to 35°C (41 ° F to 95 ° F) Humidity 10% to 90%RH (no condensation)
Non-operation	Temperature 0°C to 40°C (32°F to 104°F) Humidity 5% to 95%RH (no condensation)
Power supply	
Input voltage / Frequency	AC 100~127V 50/60Hz (LV) AC 220~240V 50/60Hz (HV)
Power consumption During printing	Approx. 14 W
Stand-by status	Approx. 1 W
External dimensions	
With paper feed/delivery tray extended	Approx. 385(W) X 422(D) X 317(H) mm
With paper feed/delivery tray set in	Approx. 385(W) X 195(D) X 165(H) mm
Weight	Approx. 2.4kg (excluding the print head and ink tanks)
Related standards	
RFI, Electrical safety	FCC, IC, CE, C-Tick, VCCI, Taiwan EMC, Korean MIC, Gost-R, UL, CUL, CB Report, GS, FT, Safety Standards, CCC, Korean EK, SASO, SPRING, TUV (ARG)

2-2. Product Life

3 years or 4,000 pages (2,500 pages of color printing and 1,500 pages of black printing), whichever comes first

2-3. Print Head Specifications

Structure	4-color integrated type (ink tank separate type)
Print head	Bk: 2 vertical lines, 320 nozzles C/M/Y: 2 vertical lines in each color, 128 nozzles Ink drop: Bk 30pl, Col 5pl
Ink colors	Bk (new pigment ink) Cl: Y, M, C (high brilliance)
Ink tank	BCI-24 Bk, BCI-24 Color (Common with S200/S200x/S300/S330)
Weight	Approx. 60g (excluding ink tanks)
Supply method	Service part (excluding ink tanks) Part number: QY6-0044-000
Print head life	4,000 pages (Same as the printer main unit, Cl: 2,500 pages, Bk: 1,500 pages of black printing)

Note: This print head can only be used in the i320 only, and cannot be used in the old model, S300/S330 series. The print head can be physically installed in the S300/S330, however the print head type is different. Similarly, the S300/S330 print head is not usable in the i320.

3. ERROR DISPLAY

Errors are displayed by the LEDs, and warnings are displayed by the status monitor.

3-1. Operator Call Error (Orange LED blinking)

LED Display	Content	Corrective Action
Blinking 2 times	Paper out	Set the paper, and press the RESUME button to feed the paper.
Blinking 3 times	Paper jam	Remove the jammed paper, and press the RESUME button.
Blinking 6 times	No cartridge installed	Install the cartridge, and close the access cover.
Blinking 7 times	Cartridge installed improperly* ¹ (Cartridge EEPROM data is abnormal.)	Re-install the cartridge properly, or power off and on the printer with the cartridge installed.
Blinking 8 times	Waste ink full or platen waste ink full warning (Approx. 95% of acceptable amount)	Press the RESUME button.

3-2. Service Call Error (Orange and green LEDs cyclical blinking)

LED Display	Content	Corrective Action
Blinking 2 times	Carriage error	Replace the printer as it has failed.
Blinking 6 times	Internal temperature abnormal error	Replace the printer as it has failed.
Blinking 7 times	Waste ink full or platen waste ink full error	Replace the printer as it has failed.
Blinking 8 times	Abnormal temperature rise	Replace the printer as it has failed.
Blinking 9 times	EEPROM error	Replace the printer as it has failed.
Blinking 10 times	No cartridge installed detection excluding the case of cartridge replacement (during printing)	Replace the printer as it has failed.

3-3. Warning (No LED display)

Content	Remarks
Black ink low warning 1 (about half amount)	Displayed in the status monitor only* ²
Color ink low warning 1 (about half amount)	Displayed in the status monitor only* ²
Black ink low warning 2 (little amount, "I")	Displayed in the status monitor only* ²
Color ink low warning 2 (little amount, "I")	Displayed in the status monitor only* ²
Black ink low warning 3 (unknown amount, "?")	Displayed in the status monitor only* ²
Color ink low warning 3 (unknown amount, "?")	Displayed in the status monitor only* ²
Head temperature rise	Displayed when the access cover is opened, the print head temperature is high* ³ When the head temperature lowers, the warning is released.
Head temperature over-rise protection	The carriage stops during printing when the head temperature is excessive.

*¹: Same as when the non-supported cartridge (print head for S300/S330) is installed.

*²: Only when the ink remaining amount detection is ON. (Status is not displayed at OFF.)

*³: Printer operation at the warning: When the access cover is opened, the carriage does not move to the cartridge replacement position.

4. SERVICE MODE

To conduct the following functions, the computer (Windows98/Me), printer driver and service tool (QY9-0058) for the i320 are needed.

Function	Procedure	Remarks
Print head cleaning	Select "Cleaning" from the printer driver utility.	Cleaning time: Approx. 40 sec.
< For reference > Head refreshing (deep cleaning)	Select "Deep Cleaning" from the printer driver utility.	Cleaning time: Approx. 70 sec.
Paper feed roller cleaning	1. Remove the paper from the ASF. 2. Select "Feed Roller Cleaning" from the printer driver utility. 3. Following the instruction from the status monitor, load 3 pages of plain paper in the ASF, and feed them.	Cleaning time: Approx. 2 min.
Test printing		
1) Nozzle check pattern printing	Select "Nozzle Check" from the printer driver utility.	Nozzle check pattern printing
< For Reference > Head alignment	1. Select "Print Head Alignment" from the printer driver utility. 2. Select the optimal value using the printed head position adjustment pattern.	Significant misalignment can be adjusted.
2) Shipment pattern printing - ROM version - No. of pages fed - Waste ink amount - Destination setting	Refer to Shipment inspection pattern* ¹ below.	Refer to Shipment inspection pattern sample* ³ below.
EEPROM reset	Refer to EEPROM reset / Destination setting* ² below.	
Destination setting (Japan/Others)	Refer to EEPROM reset / Destination setting* ² below.	

*¹ Shipment inspection pattern

- Install the print head (QY6-0044-000), and while holding down the POWER button, plug in the AC cable. (The green lamp lights.)
- While holding down the POWER button, press the RESUME button twice, and release it. (Each press of the RESUME button changes the LED color: the LED lights in orange the first time, and in green at the second time.)
- Load A4-sized paper.
- Connect the printer to the computer, select "USB PORT" using the i320 service tool (QY9-0058). (Refer to Appendix 2, i320 Service Tool.)
- Select "TEST PATTERN 1". The printer starts printing the shipment inspection pattern.

*² EEPROM reset / Destination setting

- Install the print head (QY6-0044-000), and while holding down the POWER button, plug in the AC cable. (The green lamp lights.)
- While holding down the POWER button, press the RESUME button twice, and release it. (Each press of the RESUME button changes the LED color: the LED lights in orange the first time, and in green at the second time.)
- Connect the printer to the computer, select "USB PORT" using the i320 service tool (QY9-0058). (Refer to Appendix 2, i320 Service Tool.)
- <Destination setting>
- Other than Japan: Select "1" in "SET DESTINATION".
- Japan: Select "2" in "SET DESTINATION".
<EEPROM reset>
EEPROM is reset at the same time when the destination is set.

*³ Shipment inspection pattern sample

EEPROM setting can be confirmed from the shipment inspection pattern printout.

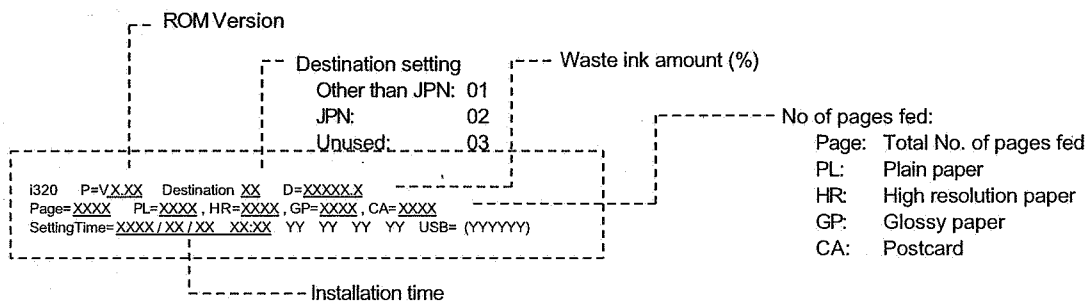

5. EXTERNAL VIEW / PARTS LIST

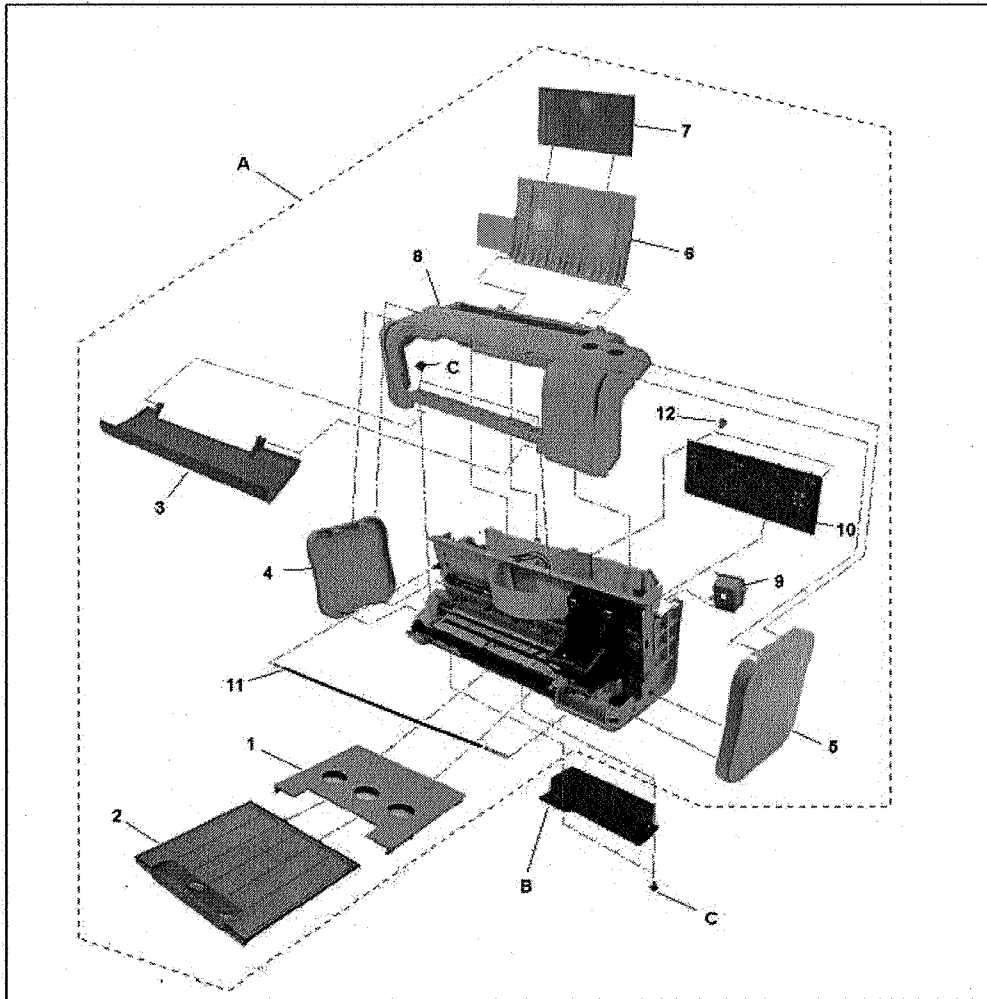

Parts List

Key	Part Number	Rank	Q'ty	Description	Remark
A	0009U22001	N	1	WHOLE UNIT, W/O POWER SUPPLY UNIT	i320
B	QH3-3561-000		1	AC ADAPTER: 100/120V 50/60HZ	LV (USA,CANADA,JAPAN)
	QH3-3563-000		1	AC ADAPTER: 220/240V 50/60HZ	HV (EUR)
	QH3-3565-000		1	AC ADAPTER: 220/240V 50/60HZ, CHN/ASIA/AUS	HV (CHN/ASIA/AUS)
	QH3-3567-000		1	AC ADAPTER: 100/120V 50/60HZ, TWN	LV (TWN)
	QH3-3568-000		1	AC ADAPTER: 220/240V 50/60HZ, KRN	HV (KRN)
	QY6-0044-000	K	1	PRINT HEAD	
C	XB4-7300-607	N	4	SCREW, PAN HEAD SELF-TAPPING, M3X6	FOR AC ADAPTER & UPPER COVER UNIT

Power cords are as listed below.

WT3-5122-000	E	1	CORD, POWER	100V-120V (J)
WT3-5131-000	E	1	CORD, POWER	100V-120V
WT3-5132-000	E	1	CORD, POWER	220V-240V
WT3-5133-000	E	1	CORD, POWER	220V-240V (AUS)
WT3-5135-000	E	1	CORD, POWER	250V (CHN)
WT3-5137-000	E	1	CORD, POWER	220V-240V (UK, HK)
WT3-5158-000	E	1	CORD, POWER	120V (LAM-LV)
WT3-5165-000	E	1	CORD, POWER	220V-240V (AR)

6. TROUBLESHOOTING FLOWCHART

6-1. Printer Main Unit Troubleshooting Flowchart (how to printer operation confirmation when refurbishing)

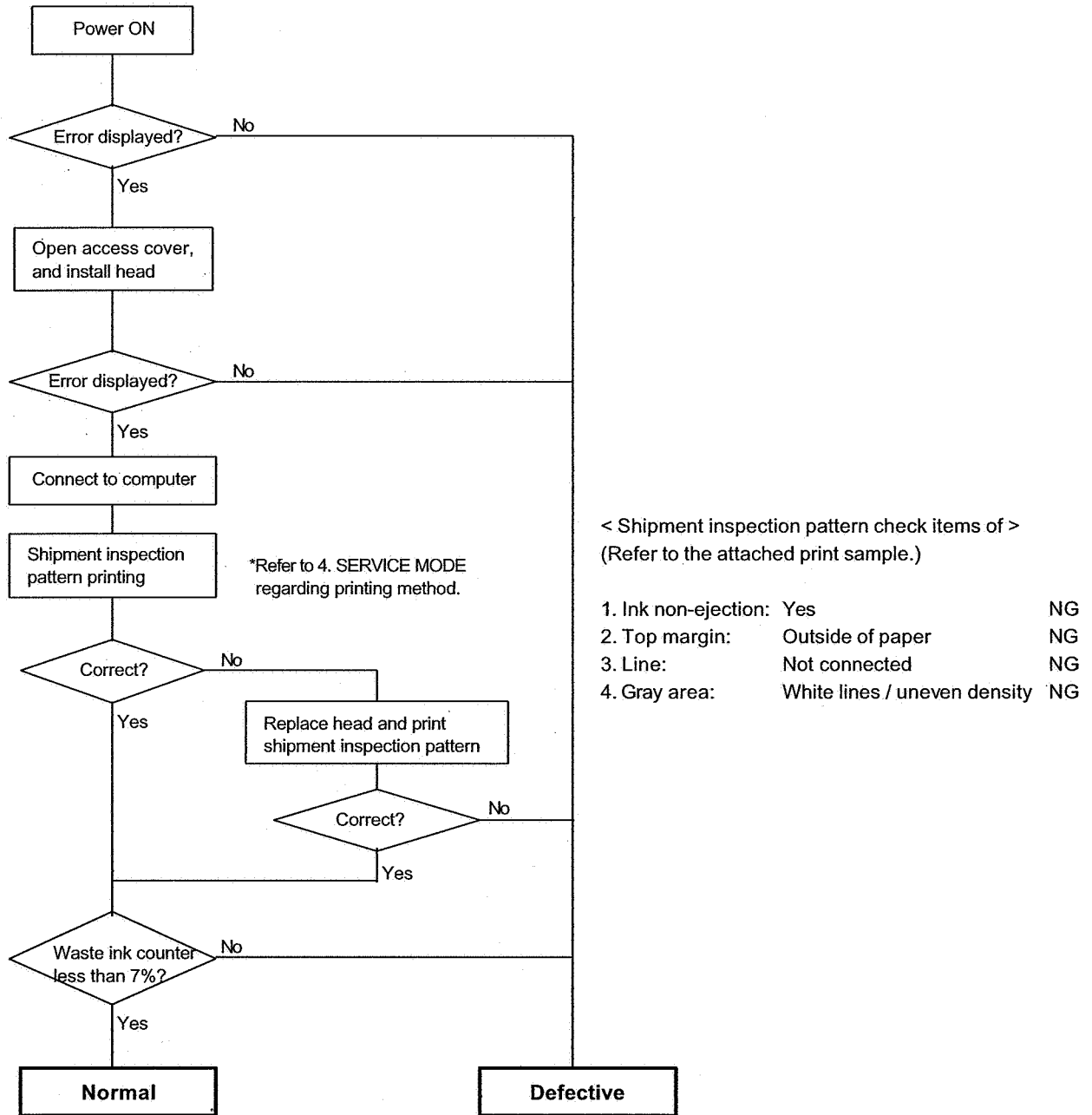

< Note for normal printer refurbishment >

At the final step of refurbishment, be sure to reset the EEPROM in accordance with 4. SERVICE MODE, the EEPROM reset procedure. Remove the print head, unplug the power cord immediately, and do not print afterwards.

6-2. Print Head Troubleshooting Flowchart (print head operation confirmation)

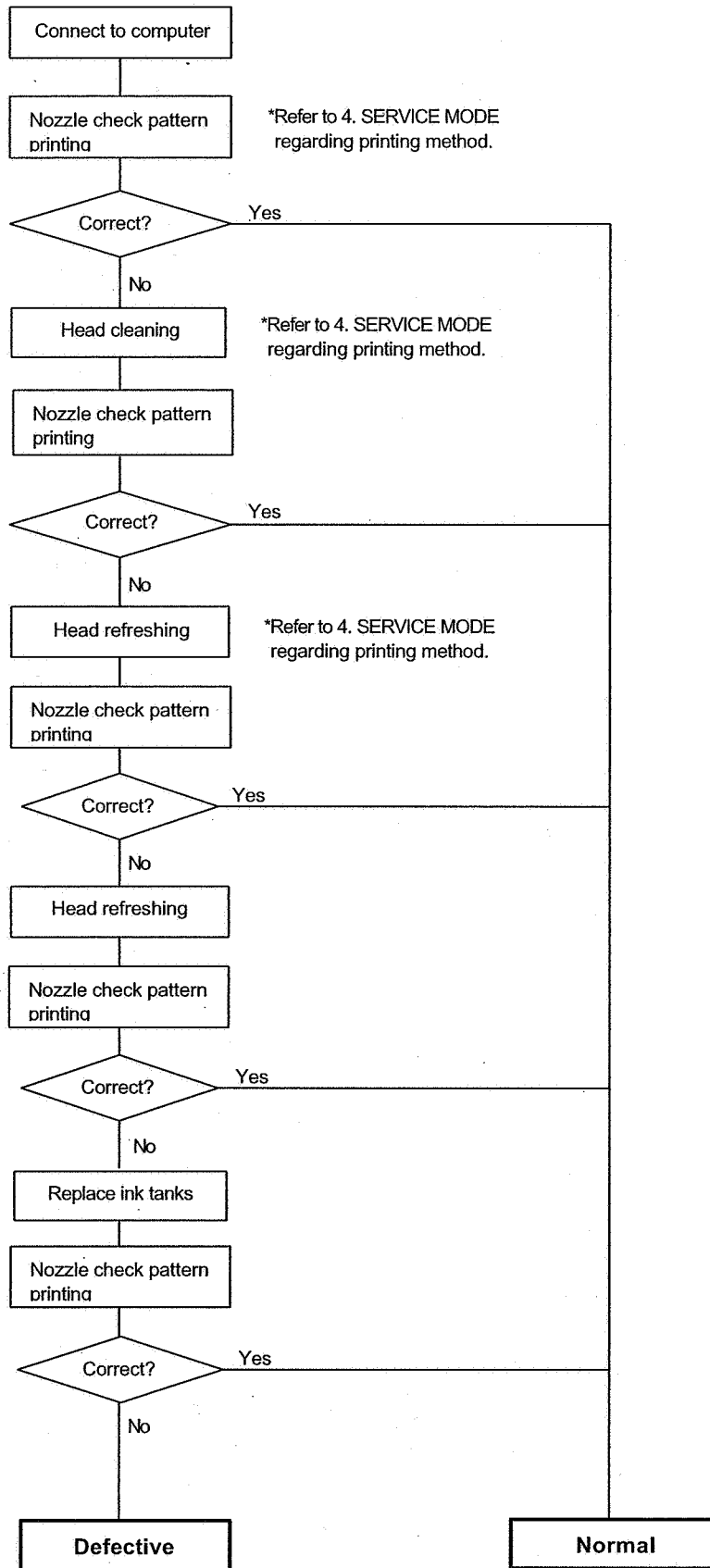

7. SERVICE INFORMATION

7-1. Whole Unit Replacement

When the unit is exchanged as a Whole Unit (WHOLE UNIT, W/O POWER SUPPLY UNIT: 0009U22001 <i320>, take the following procedures:

1. Remove the AC adapter from the printer returned from the user.
2. Install the removed AC adapter in the whole unit.
3. Perform destination setting. (Refer to "4. SERVICE MODE" for details.)
4. Power off the whole unit, and confirm that the printer ready for shipment (with the paper lifting plate of the ASF in the upper position).

< Composition of WHOLE UNIT, W/O POWER SUPPLY UNIT >

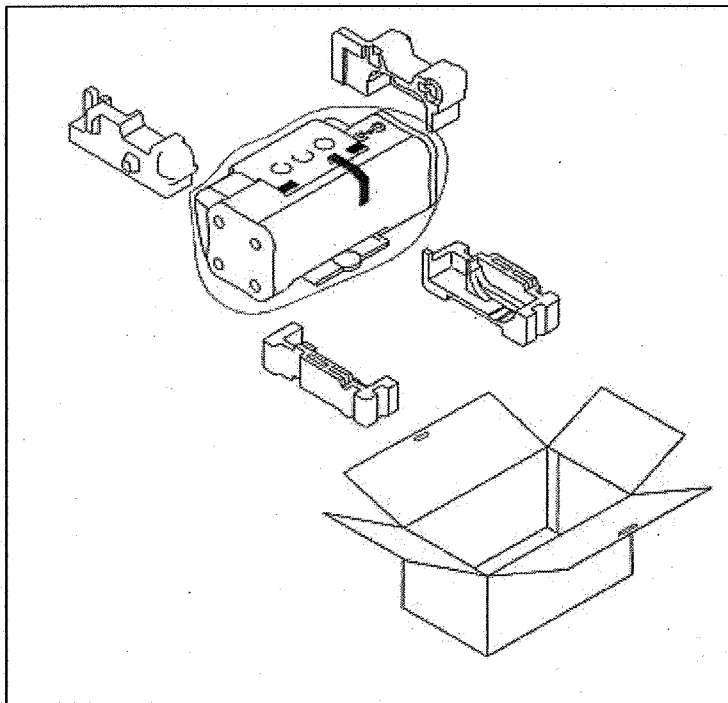

Enclosed items:

- Printer unit (without I320's access cover and AC adapter)
- Rating plate (for Asia and Oceania)
- Packing material

7-2. Product Technical Information

1) FAQ (Problems specific to the i320, and corrective actions)

No. Rank*	Function	Phenomenon	Condition	Cause	Corrective action	Possible Call / Claim
1	A	No cartridge installation error (orange LED blinks 6 times). Cartridge cannot be installed. Carriage error.	The packing material used to fix the carriage at unpacking and installation may not have been removed.	The user may have failed to remove the packing material at unpacking and installation. Although a caution sheet is packaged together with the printer, the user may not notice it. Note: Even if the packing material remains, no parts are damaged.	Remove the packing material fixing the carriage.	-LED blinks in orange 6 times (no cartridge installation error) -Cannot install the cartridge -Cannot print -LED blinks in orange and green alternately twice (carriage error)
2	A	Carriage error, abnormal noise, or paper feeding without printing.	The packing material used to fix the print head cap at unpacking and installation may not have been removed.		Remove the packing material fixing the print head cap.	-LED blinks in orange and green alternately twice (carriage error) (As this occurs at printer installation, the user cannot recognize the error.) -Abnormal noise -Cannot print -Paper feeding without printing
3	A	Abnormal cartridge EEPROM data error (orange LED blinks 7 times).	The problem likely occurs when the cartridge lever is slowly (carefully) lowered at print head installation.	When the cartridge lever is slowly lowered at print head installation, there is a timing mismatch in reading the print head EEPROM value, preventing the EEPROM value from being detected correctly. <Print head recognition mechanism> The print head installation is detected by the contact of terminals in the following procedure: 1. The existence of print head is detected. 2. The print head EEPROM value is checked.	1. Power off the printer, and re-power it on. 2. Remove the print head, and reinstall it.	-LED blinks in orange 7 times (cartridge EEPROM data error) (As this occurs at printer installation, the user cannot recognize the error.) -Cannot print
4	B	Paper not feeding when lots of paper/media is loaded. (PC101/PR101)	The problem may occur when multiple pages of PC101L and PR101 (A4/LTR) are loaded.	When the amount of paper curl is large and multiple pages are loaded, the loaded page limit level in the ASF creates friction at paper feeding.	1. Decrease the number of pages loaded in the ASF. 2. Correct the paper curl.	-Paper out error -Paper cannot be fed -Cannot print
5	B	Multi-feeding.	When multiple pages of PR101 (A4/LTR) are loaded (in the high temperature and high humidity environment).	In the high temperature and high humidity environment, the frictional force between the PR101's front and back sides becomes high, and sheets stick to each other, contributing to multi-feeding.	Set the paper one by one in the ASF.	-Multiple pages of paper are fed -Paper is delivered without printing
6	B	Envelope not feeding.	When many envelopes are loaded. <Supplement> The problem may occur with the DL envelope.	The paper feed roller slips on the paper at paper feeding. Note: Depending on the paper lots.	1. Decrease the number of envelopes loaded in the ASF. 2. Straighten out the paper (with a pen).	-Paper out error -Paper cannot be fed -Cannot print

7	B	<p>Envelop print start position shifts at top edge.</p> <p><Supplement> The top margin becomes short. In the worst cases, printing is performed onto the platen.</p> <p>Paper jam.</p> <p><Supplement> The problem occurs just after paper feeding, without printing.</p>	<p>When printing is conducted to the top edge of the printable area.</p> <p><Supplement> Remarkable in the DL envelope.</p>	<p>The paper feed roller slips on the paper at paper feeding.</p> <p>Note: Depending on the paper lots.</p>	<p>Increase the top margin.</p>	<p>-Print position shifts -Smear on the backside</p>
8	B	<p>Paper jam.</p> <p><Supplement> The problem occurs just after paper feeding, without printing.</p>	<p>The problem may occur in continuous printing of special paper (approx. 100 pages or more).</p> <p><Supplement> The problem may occur with the SP101/PR101 series.</p>	<p>Just after the LF roller starts feeding the paper, the load at the LF motor increases, causing the out-of-phase of the LF motor.</p>	<p>1. Press the RESUME button to deliver the paper. 2. Remove the jammed paper from the paper pick-up or output tray side.</p>	<p>-Paper jam error -Paper cannot be fed -Cannot print</p>
9	B	<p>Smearing on printed side.</p>	<p>The paper curl is substantial.</p> <p><Supplement> -The problem may occur with the DL and COM#10 envelopes. -The problem may occur in the address side of KH201 (after continuous borderless printing to the message side), in the high temperature and high humidity environment.</p>	<p>The edge of paper rises due to the large amount of curl, causing the print head to rub against the printed surface of paper, resulting in smearing.</p>	<p>1. Correct the paper curl. 2. Recommend the user to conduct printing in the print quality assurance area. (In the i320, the head-to-paper distance cannot be changed.) Note: In borderless printing (to postcard, L-size, 4X6), correct the paper curl.</p>	<p>-Smear on the printed side of paper -Cannot print properly -Paper edge crease</p>
10	B	<p>Smearing on the backside of paper, or smear on address side of postcards.</p> <p><Supplement> In borderless printing, vertical lines appear around the top edge of backside of printed paper. (transferred from the platen)</p>	<p>When borderless printing is conducted continuously.</p>	<p>When borderless printing is conducted continuously, ink mist attaches to the ribs on the platen, and is transferred to the backside of the following paper.</p>	<p>Clean the ribs on the platen with cotton swabs/buds.</p>	<p><When printing address side of postcards> -Smears on the address side <When printing correct side (message side) of paper> -Smears on the backside</p>

11	B	Vertical uneven print density and lines. <Supplement> Uneven print density due to the scan complement control** performed at print data break-up.	-When a low specification performance computer is used -When other applications are running -ROM version 1.00 <Supplement> Among special papers with large amount of print pattern data. Note: Comparably remarkable in the specific print pattern (a uniform pattern using single color)	When scan overflow control fails, the scan complement control** is performed at the same position repeatedly, thereby uneven print density and lines appear. (While this phenomenon occurs, the print speed slows considerably.) <Permanent countermeasure> Rectified in ROM version 1.30 onwards.	1. Close the other applications. 2. Upgrade the ROM from 1.00 to 1.30 onwards.	-Lines/uneven print density at the top edge of paper -Cannot print properly
12	C	Horizontal uneven print density and lines at the trailing edge of paper <Supplement> Problem appears within about 30mm from the trailing edge.	-When borderless printing is conducted. -When printing is conducted in "Full" to the printable area's trailing edge. Note: Comparably remarkable in the specific print pattern (a uniform pattern using single color)	When the paper end comes off the pinch roller, the paper is printed without being held, preventing the ink drops from being ejected in the correct positions, resulting in unevenness. Note: The problem is more severe than that of the S200.	Recommend printing in the print quality assurance area.	-Cannot print to the bottom edge of paper -Lines and uneven print density appear in the trailing edge of paper -Cannot print properly
13		Horizontal lines and uneven print density due to LF roller feeding at small pitch. <Supplement> Lines and uneven print density of 1 to 2mm pitches.	Special paper / standard mode. <Supplement> Paper of PR series, SP101. Note: Comparably remarkable in the specific print pattern (flesh tones and a uniform pattern using a single color)	As the print media slightly slips against the feeding amount by the LF roller, printed areas overlap, causing the problem.	Change the print quality from standard to high mode.	-Lines and uneven print density (on flesh tones and background) -Cannot print properly
14		Horizontal white lines and gaps due to LF roller.	When monochrome printing is conducted to the plain paper in the standard mode. <Supplement> Note: Comparably remarkable in the specific print pattern (black halftone graphic pattern).	The print media is slightly overfed against the feeding amount of the LF roller, causing white lines (missing) to appear. <Permanent countermeasure> The printer driver has been upgraded.	1. Change the print quality from standard to high mode. 2. Upgrade the printer driver. Win98/Me: 7.31 onwards Win2000/XP: 1.61 onwards MacOS8.6 and later: 4.11 onwards	-Print head path lines and uneven colors -Cannot print properly

*Rank

A: The phenomenon may occur at a relatively high occurrence ratio. (Caution needed)

B: The phenomenon may occur in specific conditions, however the occurrence ratio is expected to be considerably low in the actual usage.

C: As the phenomenon is hard to be recognized by general users, it is expected to cause no claims from the users.

**Scan complement control
Refer to 2) New function, 1. HAPS system below.

2) New functions

1. HAPS system

The printer adopts a HAPS system for the engine firmware, instead of the previously-used NATIVE system. With the HAPS system, a part of processing functions of the engine firmware has been transferred to the host computer processing, utilizing the computer processing to a maximum, thereby minimizing the engine firmware processing. (Processing is conducted in "OutputModule", on the printer driver side.

Assigned tasks between engine firmware and OutputModule using the HAPS system
(as different from the past engine firmware processing functions)

		Engine firm	OutputModule
1. Control command		○	-
2. Print mode		-	○
3. Print control	3-1. Usage nozzle switching (HS/HQ)	-	○
	3-2. Pass switching (HQ)	-	○
	3-3. Multi-pass (fine) control	-	○
	3-4. Power monitor (at Bk, 1 pass printing)	-	○
4. Delay control	4-1. Smear processing	○	○
	4-2. Scan delay	○	○
	4-3. Page delay	○	○
5. Borderless printing (incl. counting waste ink amount in absorber on platen)		○	○
6. Head alignment		○	○
7. Others		-	-
* Scan overflow control		○	-
** Scan complement control		○	-

* Scan overflow control

As the printer cannot store the print data for one scan in the RAM, this function allows printing to start before all print data for one scan is stored in the print buffer.

**Scan complement control (printing complement at print data break-up)

When the data transmission speed slows as a result of the computer's data processing capability and load, the print data may break up due to the implementation of overflow scanning. In this case, the print data is complemented at the next scan.

2. Borderless printing

The printer supports borderless printing only for postcard, L size paper and 4X6 size paper. Other paper sizes (A4, LTR, etc.) are not supported.

< Possible problems with this function >

- Smearing on the message side of the postcard, and smearing on the address side in continuous borderless printing
 - > Clean the ribs on the platen
- Smearing on the backside of paper in continuous borderless printing
 - > Clean the ribs on the platen
- Ink mist on the platen
 - > Clean the ribs on the platen

3. No paper selection lever

The printer does not need adjustment using a paper selection lever. (Adjustment of the head-to-paper distance when printing envelopes is not necessary.)

< Possible problems with this function >

- The head rubs against the paper when the amount of paper curl is large.
 - > Correct the paper curl. (Less than 3mm)
 - > In print modes other than borderless printing, conduct printing in the print quality assurance area of the top and bottom edges. (Top margin: 28mm, bottom margin: 26.5mm)

4. Quiet mode

The printer has a quiet mode function.

Compared with the normal mode,

Acoustic noise level:	Slightly lowers. (HQ, normal: Approx. 50dB, Quiet: Approx. 49dB)
Audible overtone level:	Sound quality changes, and sound becomes quieter.
Print speed:	Slows. (Bk printing in HQ/HS mode using an acoustic noise measurement pattern: Approx.1.3 times)

3) Other functions

1. Remaining ink level detection function

The printer has a function to detect the remaining ink level. (Default setting: ON)

Detection method: Dot counting (Counted for each Bk/CI ink tank).

CI tank: The remaining ink level is detected by total counted dot values of 3 color ink tanks.

Display method: Displayed on the status monitor (at 3 levels shown below for each Bk/CI ink tank)

Level 1: Half level of remaining ink level (Approx. 40% of ink remaining)

Level 2: Indication of "!" mark (Approx. 10% of ink remaining)

Level 3: Indication of "?" mark (Remaining ink level is unclear)

*Remaining ink detection function displays the status only, and does not cause errors.

Accuracy: The margin of error of detection accuracy is +/-10% in normal printing.

*The margin of error is likely to be large in the following specific print patterns:

When printing continuously using any one of the CMY ink tanks

-> As the remaining ink level is calculated by total counted dot values of 3 color ink tanks, if any of the C/M/Y inks is heavily consumed, the margin of error for remaining ink increases.

When performing continuous Bk solid printing

-> With continuous printing, ink flow from the tank to the ink chamber can be interrupted, after which ink remains unused in the tank.

Display procedure: Perform the following operations from the printer driver utility.

1. Set the indication of the remaining ink level in "Low Ink Warning Setting".

2. Reset the ink counter in "Ink Counter Reset".

*Be sure to reset the ink counter from the printer driver utility after replacing ink tanks.

< Possible problems with this function >

- Due to user error, the actual remaining ink level does not match the indicated remaining ink level, resulting in "ink out", etc.

User error: Forgetting to reset ink counter / ink counter reset other than when replacing ink tanks.

- Due to the specific print pattern, the actual remaining ink level does not match the indicated remaining ink level, resulting in "ink out".

Specific print pattern: Continuous printing using any one of the CMY ink tanks / continuous Bk solid printing, etc.

2. Head refreshing

The printer has a head refreshing function.

Head refreshing: This is a deep cleaning function in order to resolve print failure due to ink clogging the print head. (The black ink is pigment-based, and clogs easier than the current dye-based ink.)

*Perform from the printer driver utility.

< Possible problems with this function >

- Excessive ink consumption when conducting head refreshing repeatedly. (The amount of ink used is approx. 10 to 15 times the normal manual cleaning amount.)

< Reference >

Cleaning types, amount of ink used and time required *Bk and Cl ink suction is simultaneously performed.

Cleaning type	Amount of ink used	Time required
Manual cleaning Dot count cleaning Timer cleaning (24 hours to 2 weeks)	Bk: Approx. 0.15g Cl: Approx. 0.15g	Approx. 40 sec.
Head replacement Ink tank replacement Cleaning when the head is not capped at printer power on	Bk: Approx. 0.30g Cl: Approx. 0.30g	Approx. 45 sec.
Cleaning on arrival at user Timer cleaning (2 weeks to 3 months)	Bk: Approx. 0.45g Cl: Approx. 0.45g	Approx. 60 sec.
Head refreshing Timer cleaning (3 months or more)	Bk: Approx. 1.5g Cl: Approx. 2.2g	Approx. 70 sec.

3. Head alignment

The printer has a head alignment function (head position adjustment function). (The adjustment is needed at the initial set-up by the user.)

Head alignment: This is a function to correct the displacements between the nozzle lines of the print head, and incorrect print position at bi-directional printing. The adjustment is conducted using the printed head position adjustment pattern.

A: Head alignment between black nozzle lines

B: Head alignment between cyan nozzle lines

C: Head alignment between magenta nozzle lines

D: Head alignment in bi-directional black printing

E: Head alignment in bi-directional color printing

F: Head alignment between black and color printing

*Perform from the printer driver utility.

(At initial set-up by the user, instruction on performing the head alignment are displayed in the status monitor.)

APPENDIX 1: SHIPMENT INSPECTION PATTERN

Check item 1 (Ink non-ejection): Total area of the sample below

Check item 2 (Top margin)

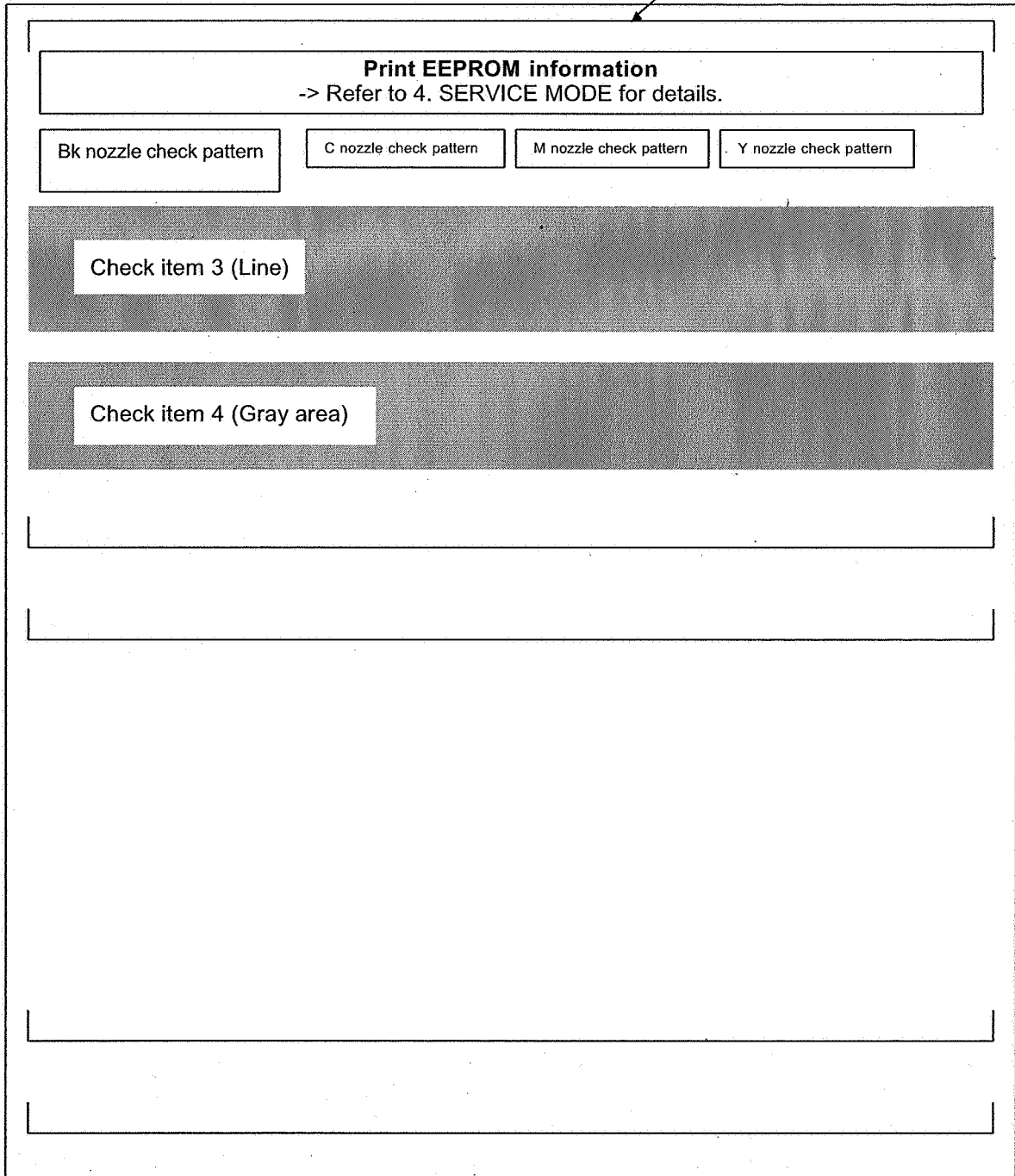

Paper size: A4

APPENDIX 2: i320 SERVICE TOOL

< How to use the i320 Service Tool (QY9-0058) >

Usage: Shipment inspection pattern printing
Destination setting in EPROM
EEPROM reset

Supported OS: Windows98/Me (J/E version) Other operation systems are not supported.

Distribution method: Provided by QISS (Download "i320 Service Tool" <Ref. RQ-T01-A18-000130> from software download in QISS.)

< Usage procedures >

1. Unzip the "i320 toolV100.EXE" file. (Automatically unzipped by double-click)
2. Open the "i320 toolV100" folder created after unzipping.
3. Open the "GeneralTool.exe" file.

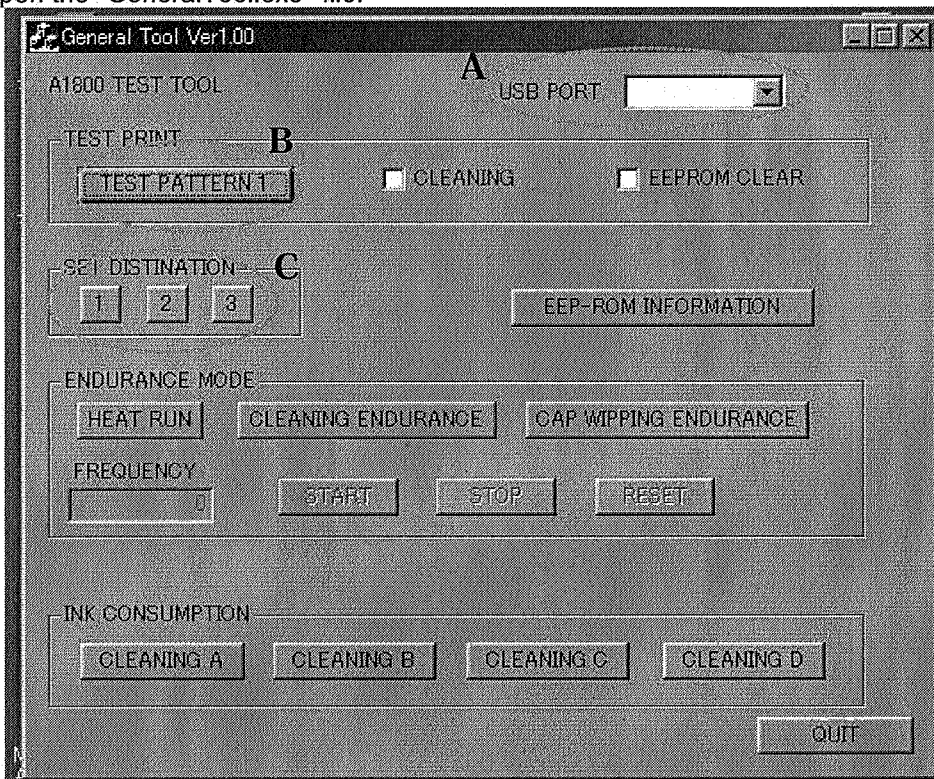

4. Select the connected USB PORT No. from "USB PORT" (A).

< How to print the shipment inspection pattern >

Select "TEST PATTERN 1" (B), and the shipment inspection pattern will be printed.
(Refer to APPENDIX 1, SHIPMENT INSPECTION PATTERN.)

< How to set the destination >

1. Select either of "1" or "2" from "SET DESTINATION" (C), and the destination will be set.
 - "1": Other than Japan
 - "2": Japan
 - "3": Unused (no destination setting)
2. Confirm the destination setting in the shipment inspection pattern printout.

< EEPROM reset >

Same as <How to set the destination>. The EEPROM will be reset by the destination setting.

Note: Even if the "EEPROM CLEAR" check box is marked, the waste ink counter will not be reset.